



**BOART
LONGYEAR** IM



**Toronto Presentation
November 2009**

© 2009 Boart Longyear. All rights reserved.

Disclaimer

This presentation has been prepared by Boart Longyear Limited (the “Company”). It contains general background information about the Company’s activities current as of the date of the presentation. It is information given in summary form and does not purport to be complete. The distribution of this presentation in jurisdictions outside Australia may be restricted by law and you should observe any such restrictions.

This presentation is not (and nothing in it should be construed as) an offer, invitation, solicitation or recommendation with respect to the subscription for, purchase or sale of any security in any jurisdiction, and neither this document nor anything in it shall form the basis of any contract or commitment. The presentation is not intended to be relied upon as advice to investors or potential investors and does not take into account the investment objectives, financial situation or needs of any particular investor. All investors should consider such factors in consultation with a professional advisor of their choosing, when deciding if an investment is appropriate.

The Company has prepared this presentation based on information available to it, including information derived from publicly available sources that have not been independently verified. No representation or warranty, express or implied, is made as to the fairness, accuracy, completeness, correctness or reliability of the information, opinions and conclusions expressed.

Any statements or assumptions in this presentation as to future matters may prove to be incorrect and differences may be material. This presentation should not be relied upon as a recommendation or forecast by the Company. To the maximum extent permitted by law, none of the Company, its directors, employees or agents, nor any other person accepts any liability, including, without limitation, any liability arising from fault or negligence on the part of any of them or any other person, for any loss arising from the use of this presentation or its contents or otherwise arising in connection with it.

Due care and attention should be undertaken when considering and analysing the financial performance of the Company. All references to dollars are to United States currency unless otherwise stated.

Welcome
Steve Deck – Regional Vice President

Logistics

 Safety / Fire Exits

 Location of information rooms

 Plant tour information

 Washrooms

 Refreshments



Agenda

3:00 p.m. **Welcome Remarks**
Steve Deck, Regional Vice President

Guest Speaker: Jason Goulden
Vice President, Minerals Economics Group
Industry Review and Outlook

Boart Longyear Global Business Overview
Craig Kipp, Chief Executive Officer
Joe Ragan, Chief Financial Officer
John Heskett, Vice President, Investor Relations

Guest Speaker: Chris Hodgson
President, Ontario Mining Association
The Mining Industry from a Local Perspective

5:00 p.m. **Plant Tour 1**
5:20 p.m. **Plant Tour 2**







Information rooms will be open from 4:50 p.m. to 5:30 p.m.

- **Investor Relations / Finance** **Boardroom 1**
- **Drilling Services** **Boardroom 2**
- **Products / Engineering** **Boardroom 3**

H'orderves and cocktails from 5:00 p.m.



BLY Canada Overview

-  871 Employees
-  2 Manufacturing Plants
 - Mississauga / North Bay
-  3 M&E Drilling Services Locations
 - Underground
 - Surface
 - Rotary
-  5 Product sales & distribution centres
-  2 E&I Drilling Services Locations
-  Mississauga Head Office

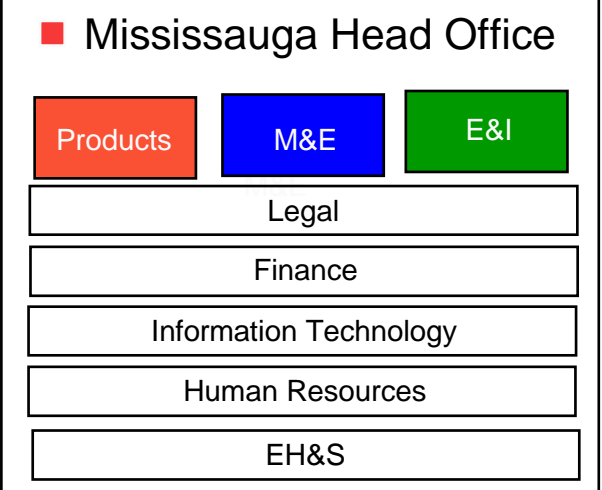
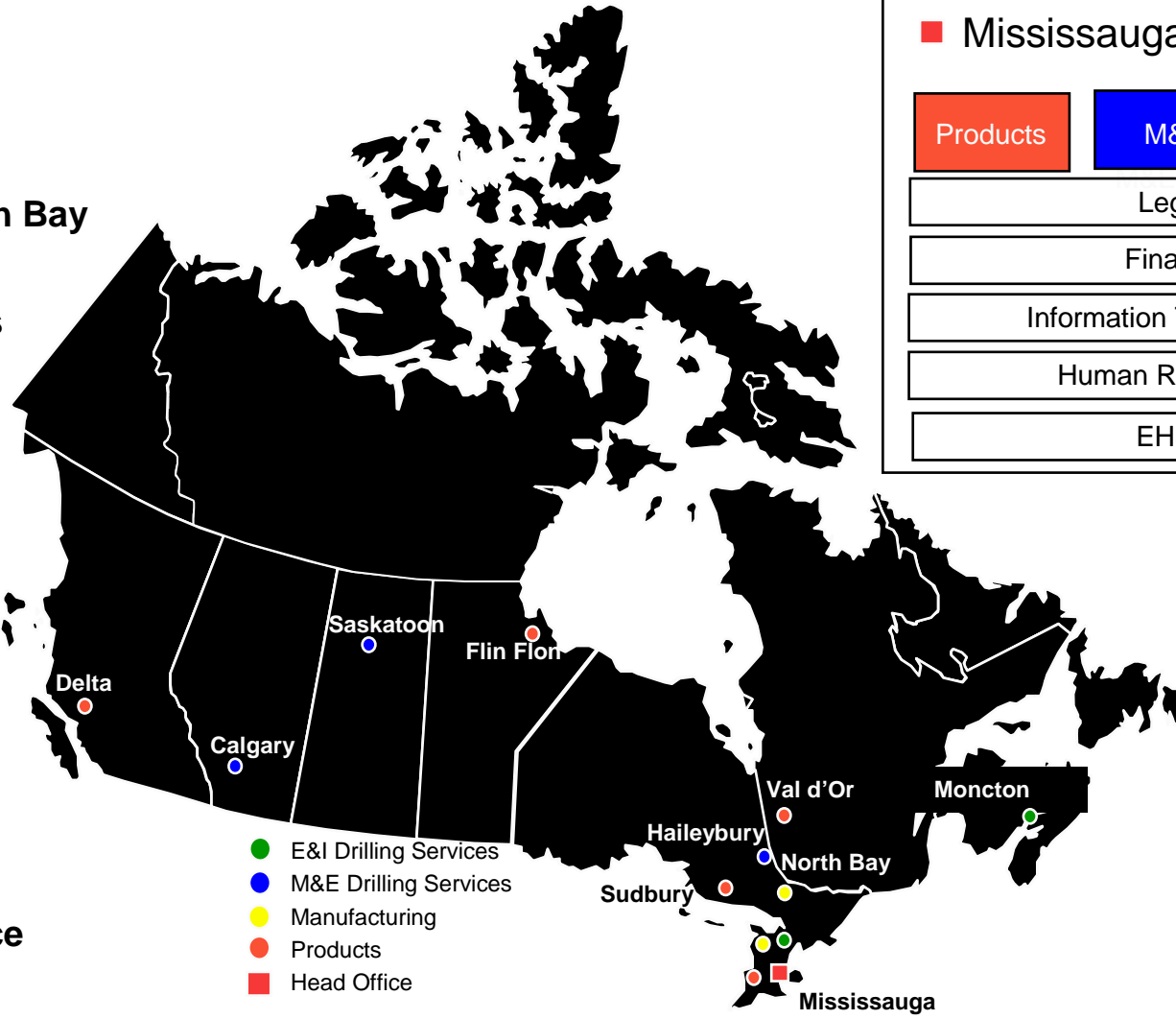







Canadian Business Overview

M&E Drilling Services

Total Drills: 257

-  **SURFACE CORING**
88 Rigs
-  **UNDERGROUND CORING**
79 Rigs
-  **PERCUSSIVE DRILLING**
60 Rigs
-  **ROTARY/SONIC DRILLING**
30 Rigs

Products

5 Sales and Distribution Centres across Canada

- CORING TOOLS** 
- DIAMOND PRODUCTS** 
- DRILLING CAPITAL EQUIPMENT** 
- AFTER MARKET SERVICES** 
- PERCUSSIVE TOOLS** 

E&I Drilling Services

Total Drills: 17



Company Overview

Craig Kipp - CEO

BLY Deliverable...



 Value to Client = Core in Box

Revenue Segmentation...\$1.8 billion

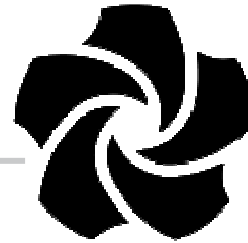

67%

33%

2008 total revenue – US\$1.8bn
Total current employees – 6,700

Drilling Services





M&E



E&I

Drilling Products

Consumables

Capital Equipment

-  Mineral Exploration and Production
-  Energy
-  Environmental
-  Infrastructure

-  Drilling Consumables
-  Capital Equipment

Customers

Resource companies

Environmental consultants

Mineral drillers

 **BOART LONGYEAR™**

Integrated Business Model.. Two Customers

Drilling Services

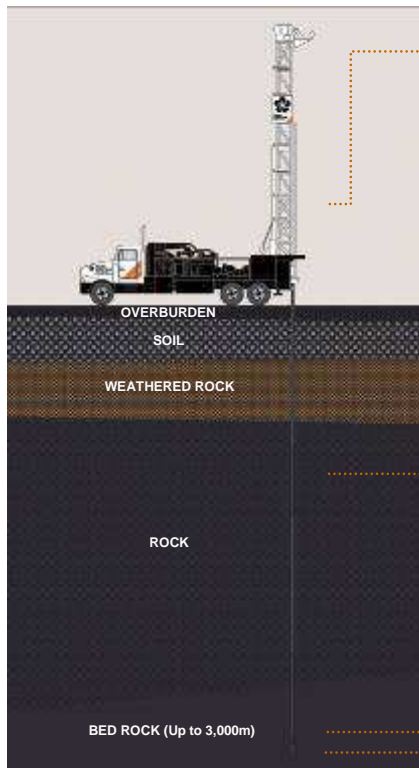

Products



Diamond Core Drilling Rig



Drill Rod String



Core Barrel System



Diamond Core Drill Bit

Drilling Services' key customers



Products' key customers



Corporate History and Milestones

 Company traces its roots to 1890...Northern Minnesota

 Spun out of Anglo American in 2005

 IPO in Australia in 2007

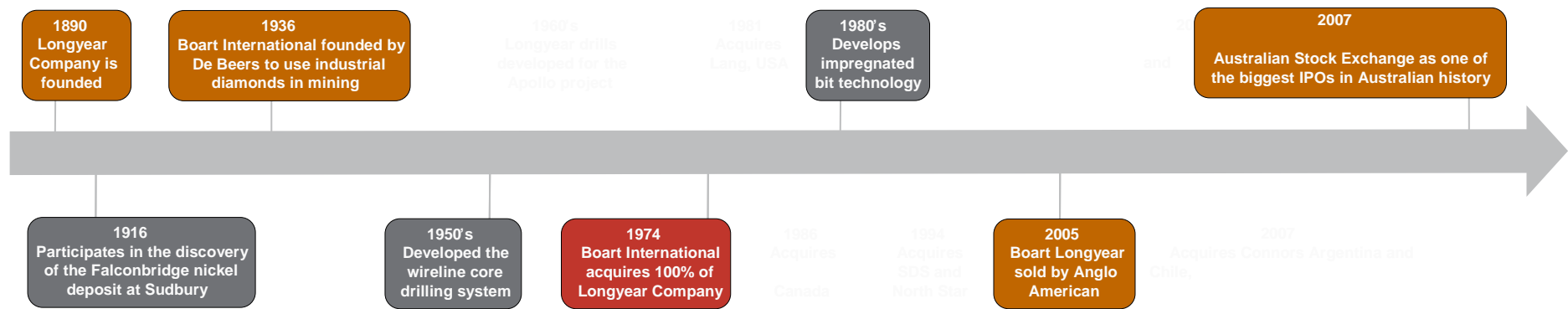

	Company milestones
	Acquisitions
	Technology advances

Diversified Business Model (2008 Sales)

Total Company by geography

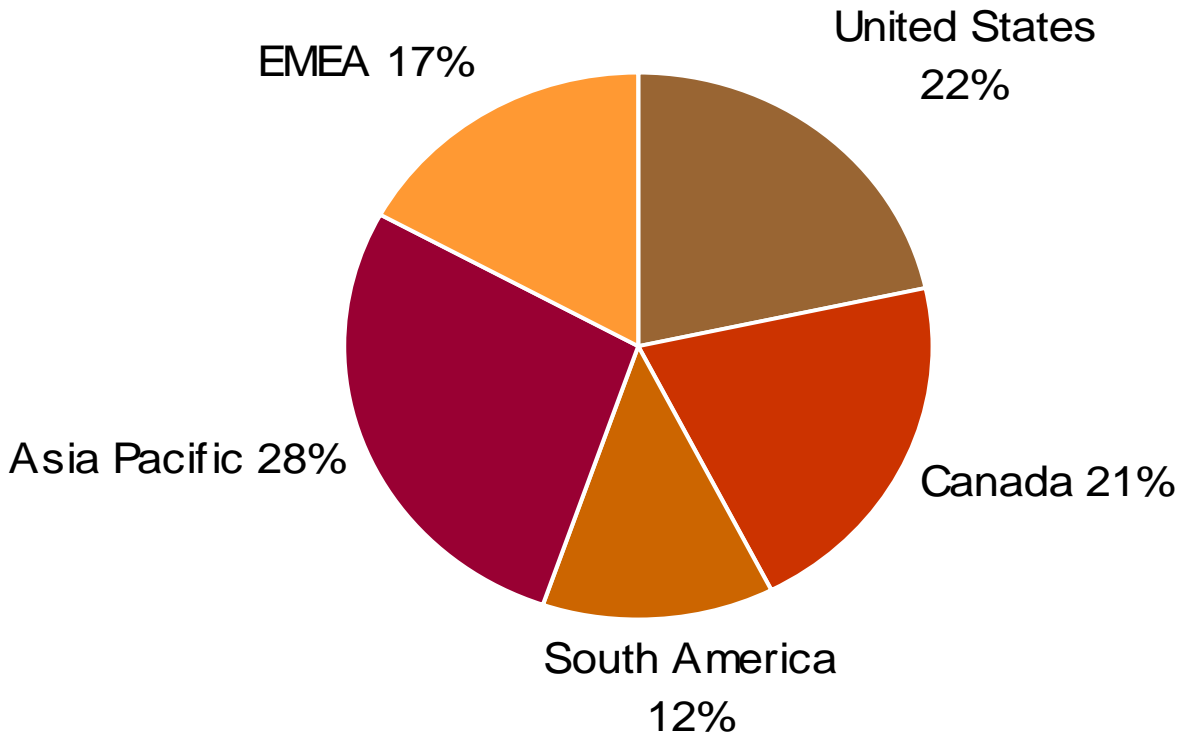

-  **Global Revenue Base**
-  **Listed on ASX in Sydney**
-  **Corporate Team in Salt Lake City**
-  **Regional Team in each regional Geography**

Drilling Services Global Fleet

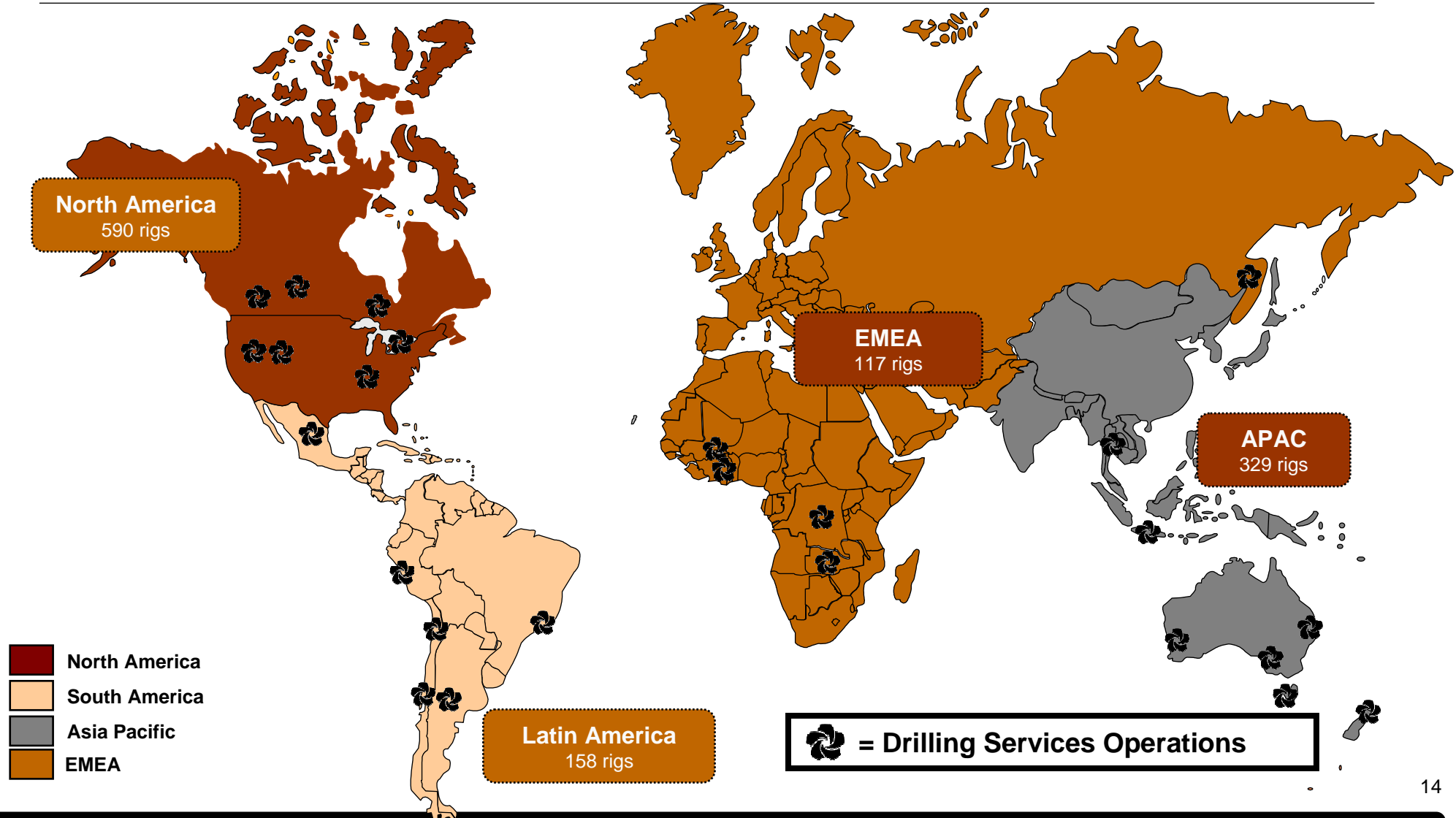



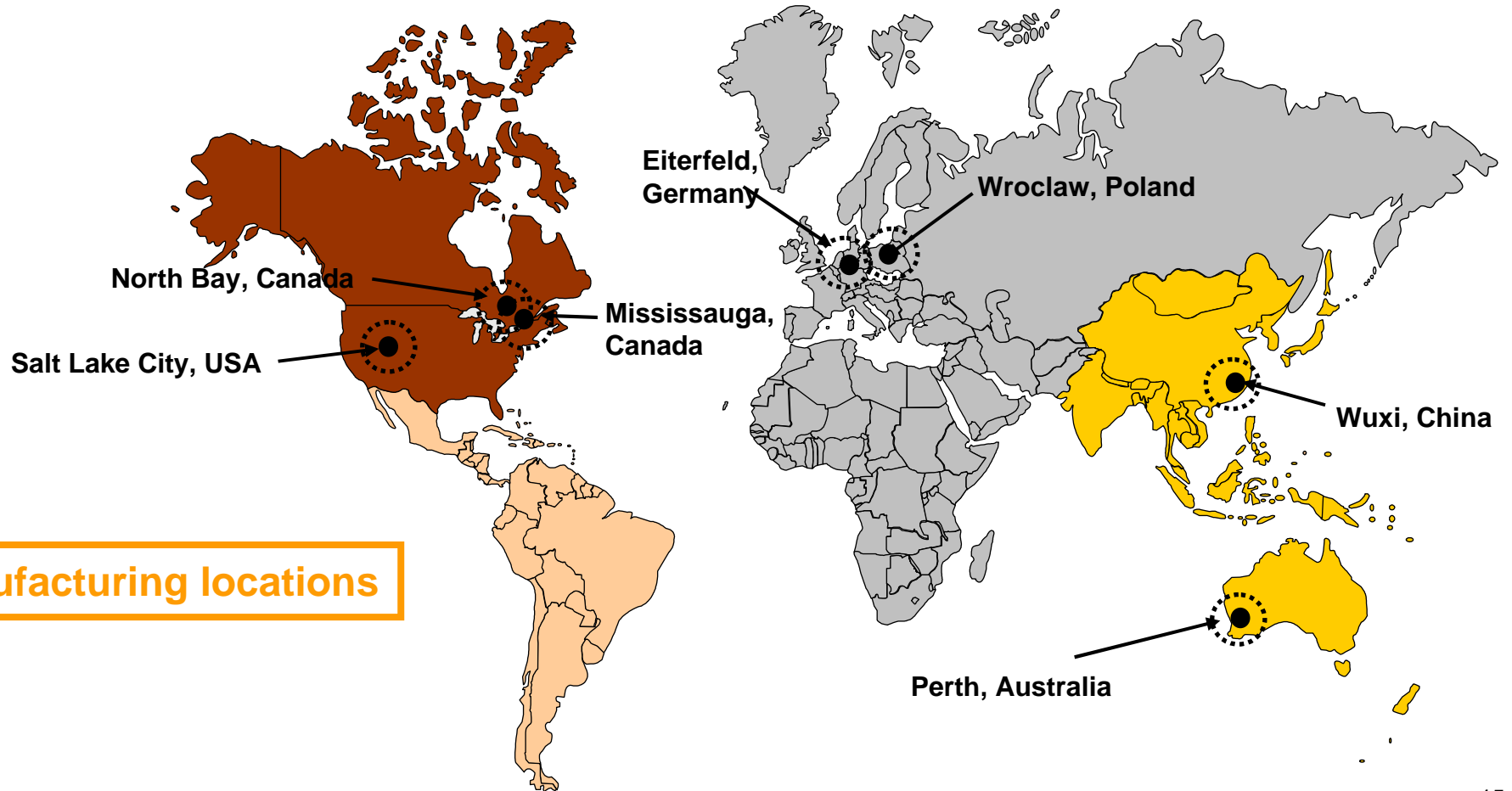





Manufacturing Footprint



7 manufacturing locations

Market Position and Competitors

Division	Segment Served	Sample Competitors
M&E	Mineral exploration & production	  
E&I	Environmental (US)	  
	Water (US)	
	Construction (US)	
Products	Minerals & energy products	 
	Production products	

Revenue by Mining Stage

23%

49%

28%



Resource Definition

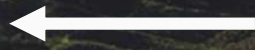

Active Pit Production



Brownfield



Greenfield



Active Underground Pit



 **BOART LONGYEAR**™

Company confidential – unauthorized use or distribution prohibited

®

Industry Leader in Safety

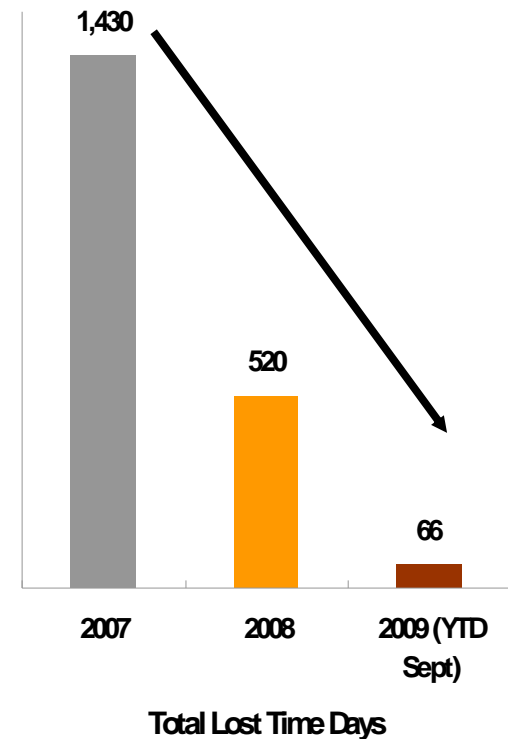
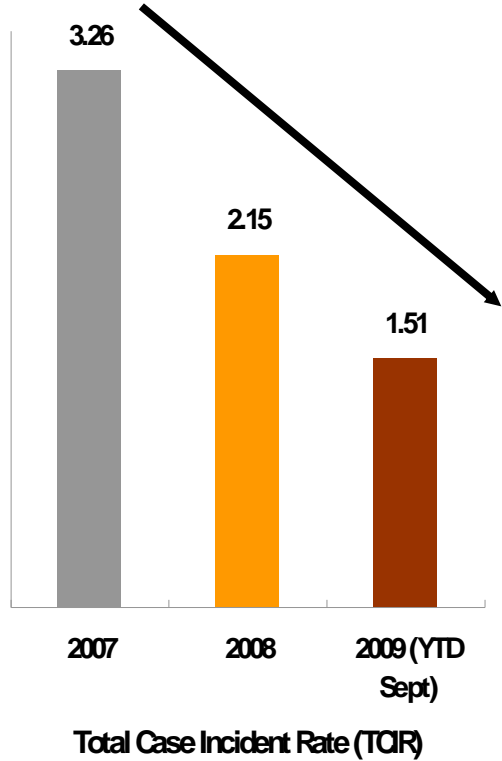
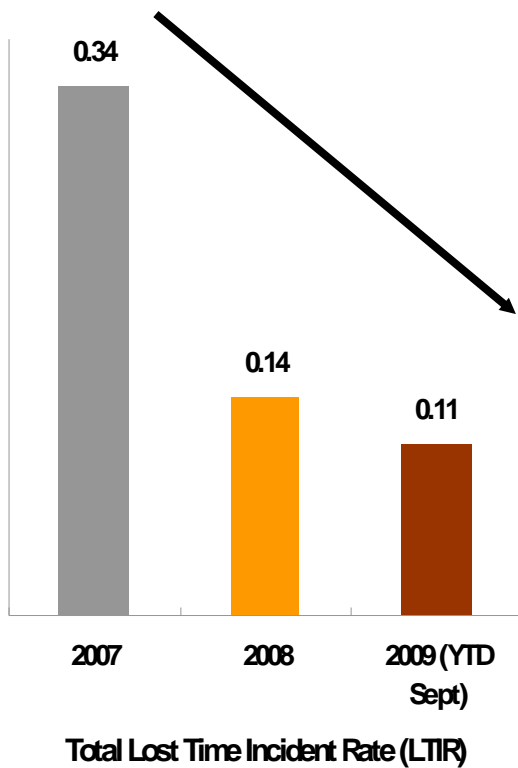

 Significant competitive differentiator with the Majors

 97% of all locations have operated YTD 2009 without a lost time incident

Safety record is among the best in ASX

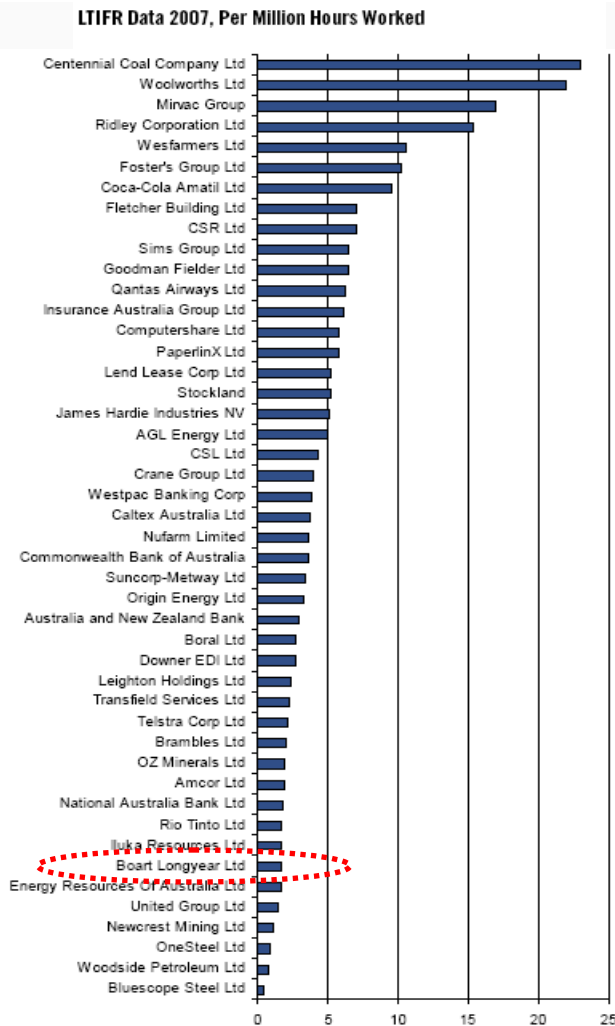

Source: Citi Investment Research and Analysis, Companies

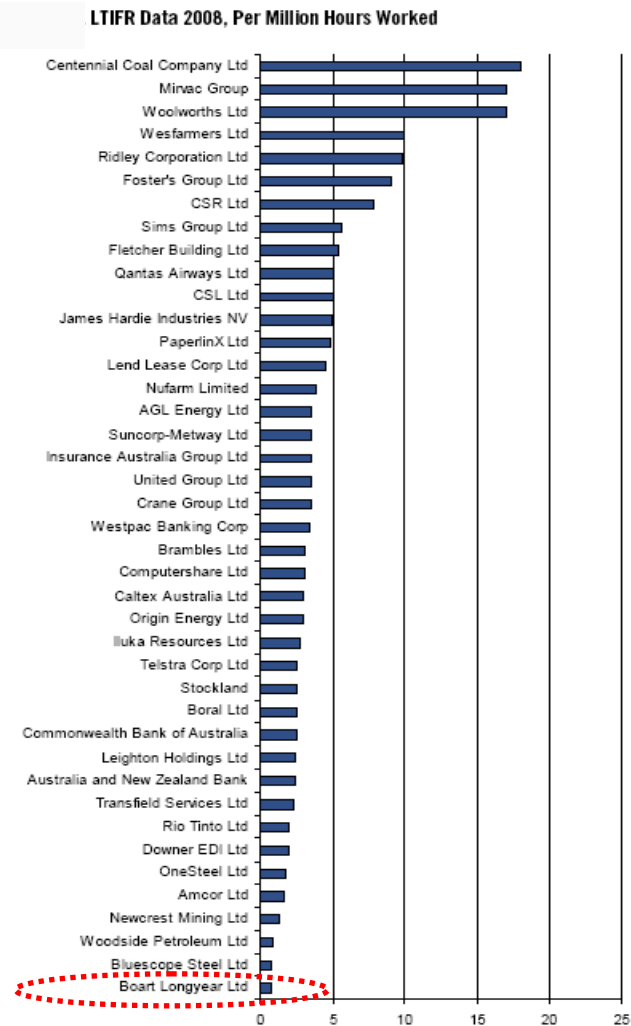

Source: Citi Investment Research and Analysis, Companies

Investor Relations Overview

John Heskett – VP, Investor Relations

Overview

 Listed on the ASX with 2007 IPO

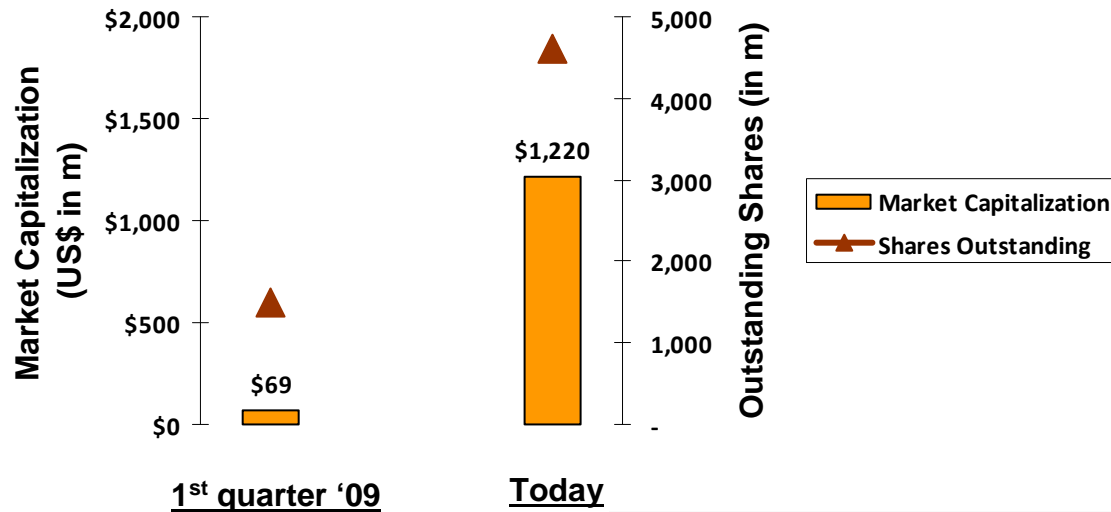

 Top Shareholders include:

Comgest

Maple Brown Abbott

Pala Investments

Ausbil Dexia

AMP Capital

COMGEST

PALA



MAPLE-BROWN ABBOTT
Investment Managers

25 YEARS
1984 - 2009
Managing Client Funds

Shareholder Base

Location

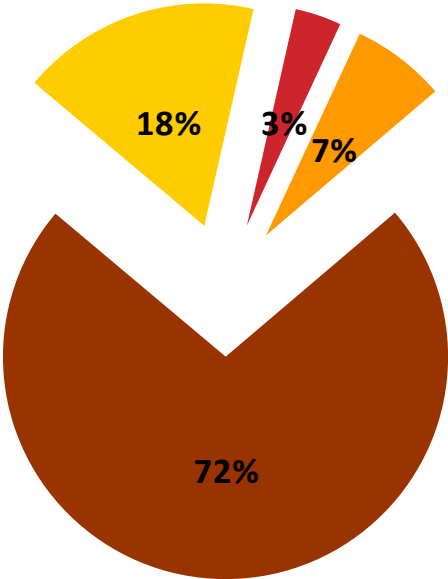

■ Europe ■ US ■ Asia ■ Aus / NZ

Investor Type

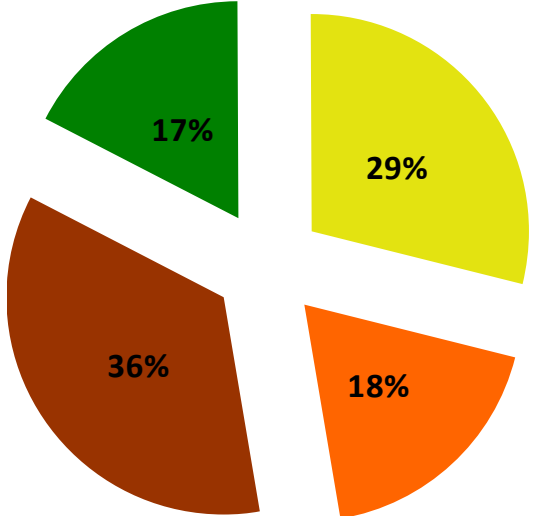

■ Retail ■ Hedge Funds
■ Aust./NZ Long Institutions ■ Non-Aust./NZ Long Institutions

Analyst Coverage 11 analysts based in Australia

ANALYST COVERAGE

Firm	Analyst	Phone	E-Mail
 Foresight Securities	Adam Michell	61-2-9235-7412	asm@foresightsecurities.com.au
 Merrill Lynch	Nicholas Robison	61-2-9226-5096	nicholas_robison@ml.com
 RBS The Royal Bank of Scotland	Richard J. Johnson	61-2-8259-5947	richard.j.johnson@rbs.com
 Austock Group Securities	Craig Stranger	61-3-8601-2010	cstranger@austock.com
 JPMorgan	Andrew Scott	61-2-9220-7894	andrew.qe.scott@jpmorgan.com
 Goldman Sachs JBWere	Chris Savage	61-2-9321-8513	chris.savage@qsibw.com
 UBS	Ramoun Lazar	61-2-9324-3156	ramoun.lazar@ubs.com
 Credit Suisse	Rohan Gallagher	61-2-8205-4858	rohan.gallagher@credit-suisse.com
 Deutsche Bank	Philip Pepe	61-2-8258-3456	philip.pepe@db.com
 Macquarie	John Purtell	61-2-8232-8633	john.purtell@macquarie.com
 Citigroup	Julian Bu	61-2-8225-4818	julian.bu@citi.com

Financial Review

Joe Ragan - CFO

Net Debt Position

Net Debt Position (US\$m)

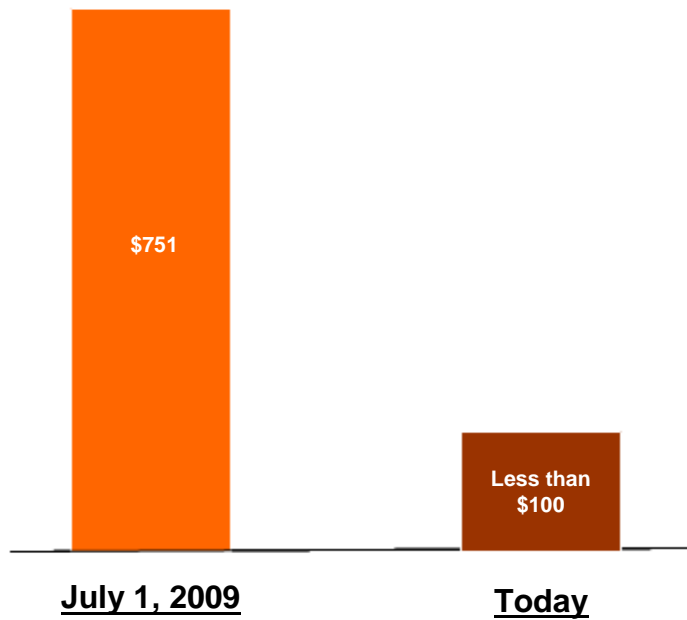

July 1st Maturity Profile

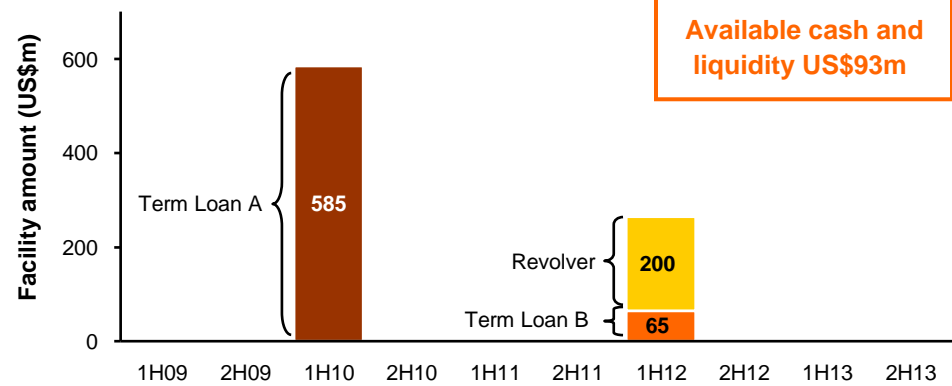

Current Debt Maturity Profile

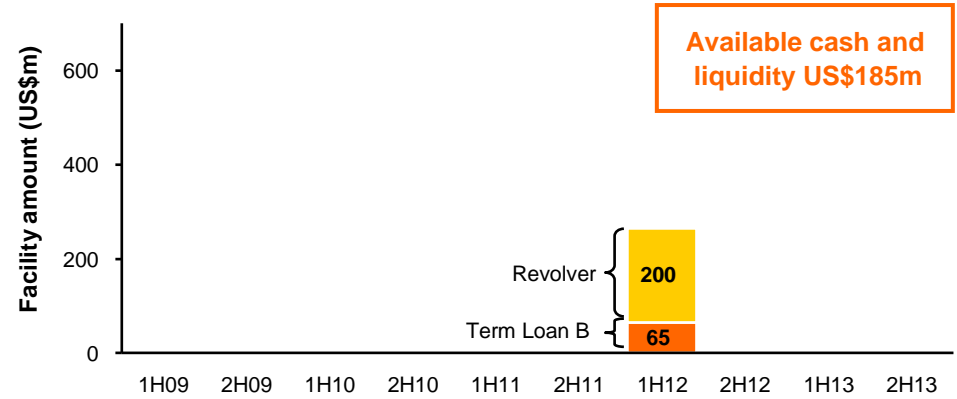



Equity Raising Sources and Uses

Sources:	US\$m	Uses:	US\$m
Entitlement Offer	341	Repay existing Term Loan A	585
Unconditional Placement	101	Repay Revolver	75
Conditional Placement	193	Estimated fees & expenses	50
SPP	75		
Total	710	Total	710

1H2009 Financial Overview

US \$M	1H 2008	1H 2009	'09 / '08 % change
Revenue	985	463	-53%
Adjusted EBITDA	215	63	-71%
<i>Adjusted EBITDA Margin %</i>	22%	14%	
 Adjusted Cash from Operations	47	42	-11%

1H2009 Highlights

-  **Lower revenues**
 - lower rig utilisation
 - decreased Products volumes
 - adverse FX impact
-  **SG&A down by 39% ...cost savings**
-  **Cash flow benefitted from working capital release**

The Business Has Been Re-Sized...

Business restructuring has reduced costs to align with new revenue base.
Operating leverage is significant.

Headcount

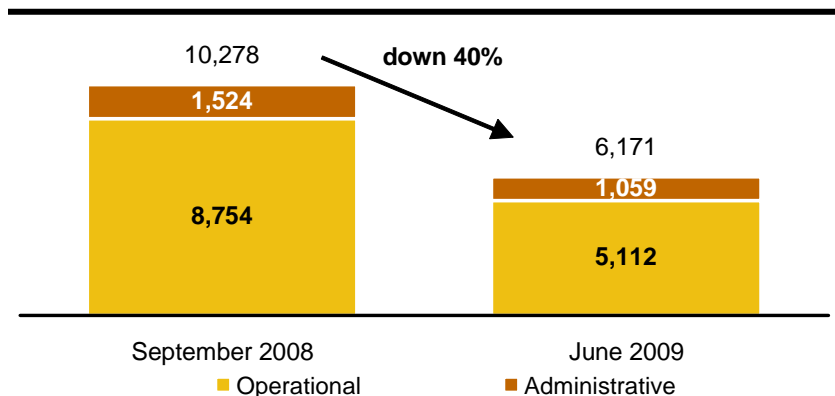

SG&A – annualised (US\$m)

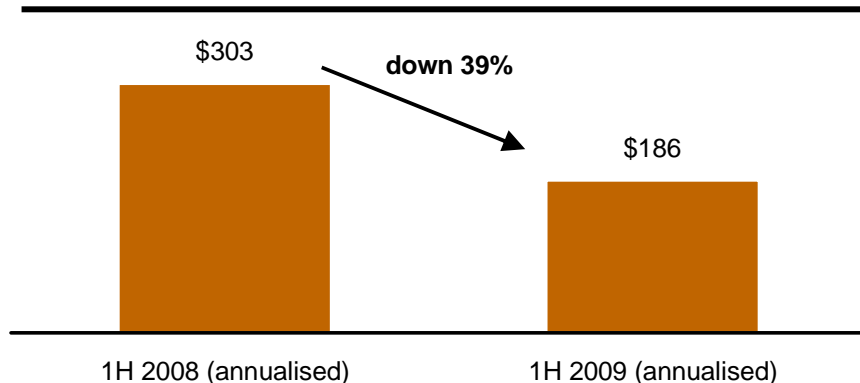

Outlook

2009

- 2009 revenue decline expected to approach 50% vs. record 2008
- 2009 Adjusted EBITDA margin expected to be approximately 13%

2010

- Revenue growth of approximately 15% is reasonable
- Reduction in customer inventories of drilling consumables assumed to be completed by year end 2009
- Level of resources sector financing activity should support additional exploration spending
- Continued gradual recovery in rig utilisation rate

Acquisition and Divestiture History

Divestitures have focused the portfolio on the core.....

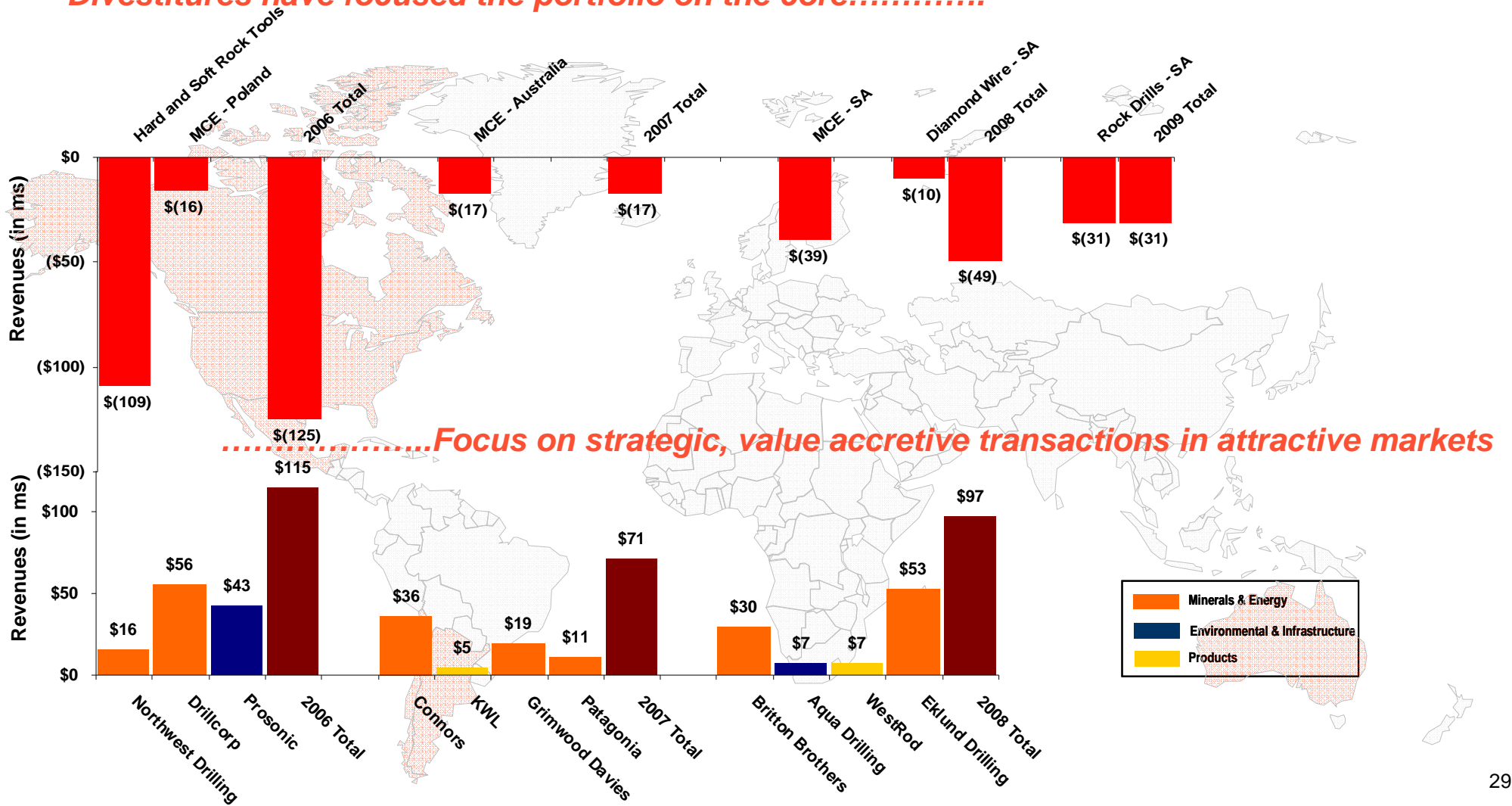

Historical Margin Progression

Business positioned to return to historic levels of profitability as cycle recovers

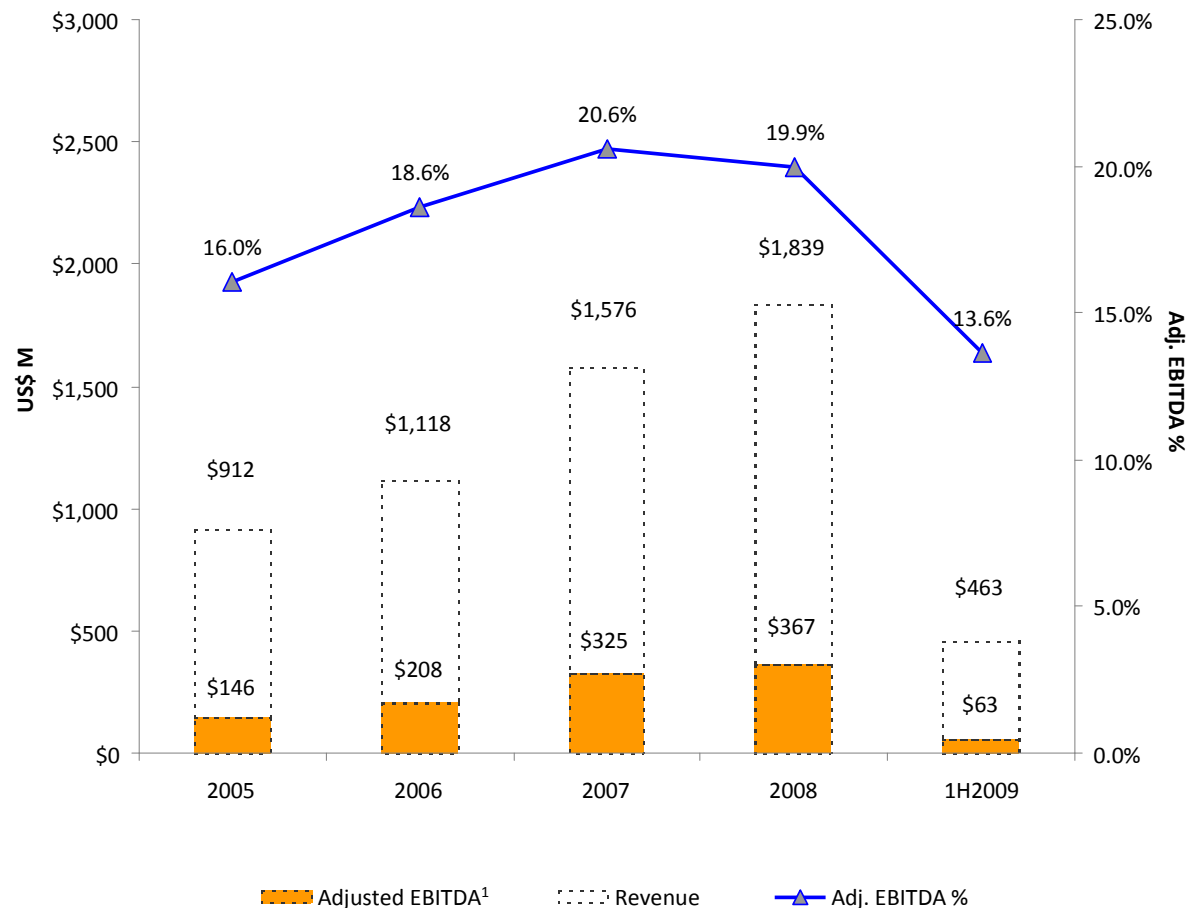

-  Business successfully resized to a lower cost base
-  Credit markets improving
-  Customers have/are raising capital
-  Capacity to meet increased drilling demand (services & products)
-  Quoting activity increasing

1. See Appendix for further details.

Minerals and Energy (M&E) Drilling Services

M&E Drilling by Primary Mineral Type *

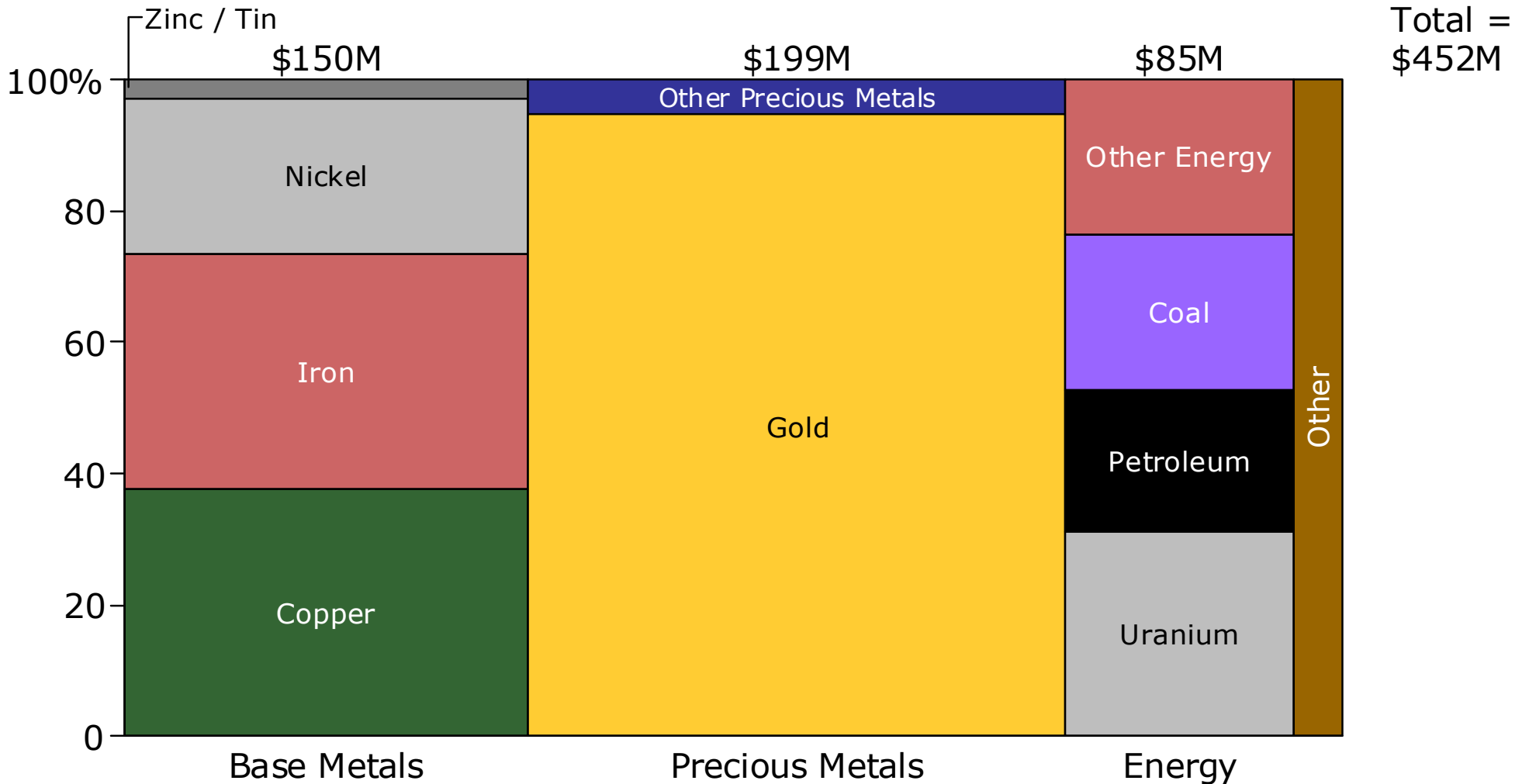

* Based on 2009 M&E's revenues through Sept 30. Exposure determined by primary target mineral at subject project

M&E Customers...82% Majors *

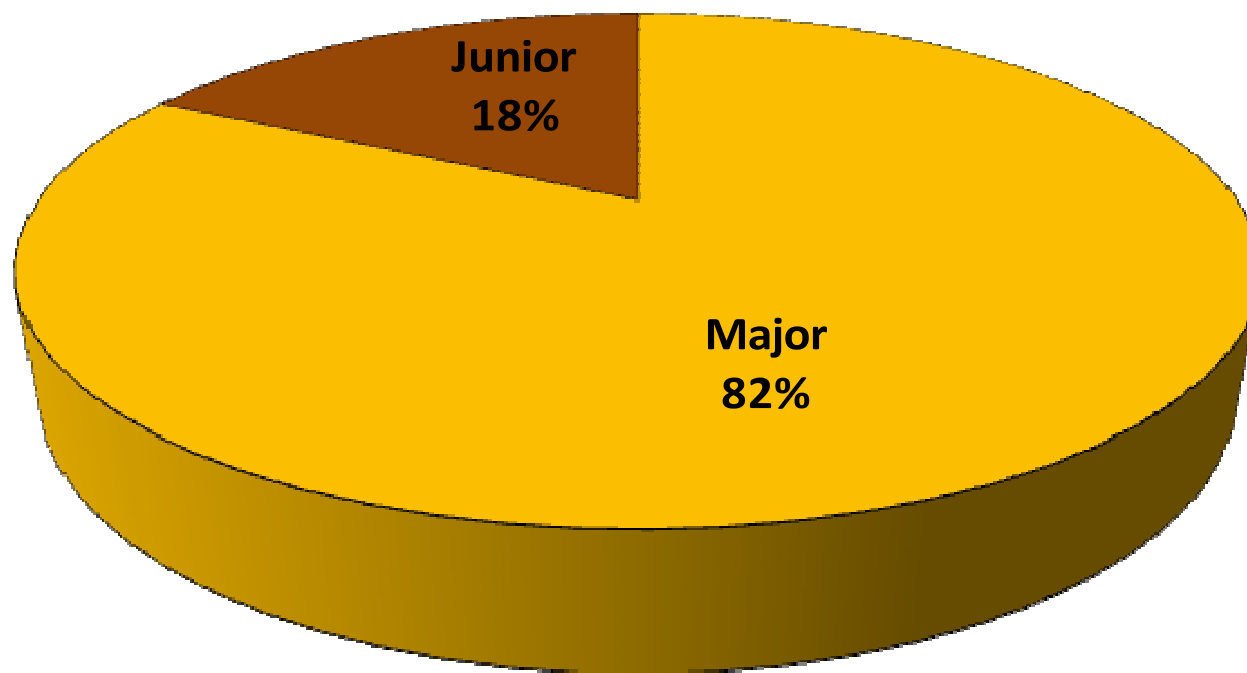

Customer Definition:

Major: Demonstrated financial strength to independently develop a resource, can sustain exploration investment with revenue generated from development of its own resources

Junior: Primarily engaged in exploration-related activities, principal means of exploration funding is through equity

33

M&E Drilling Services vs. Competition

Minerals Exploration Global Market¹

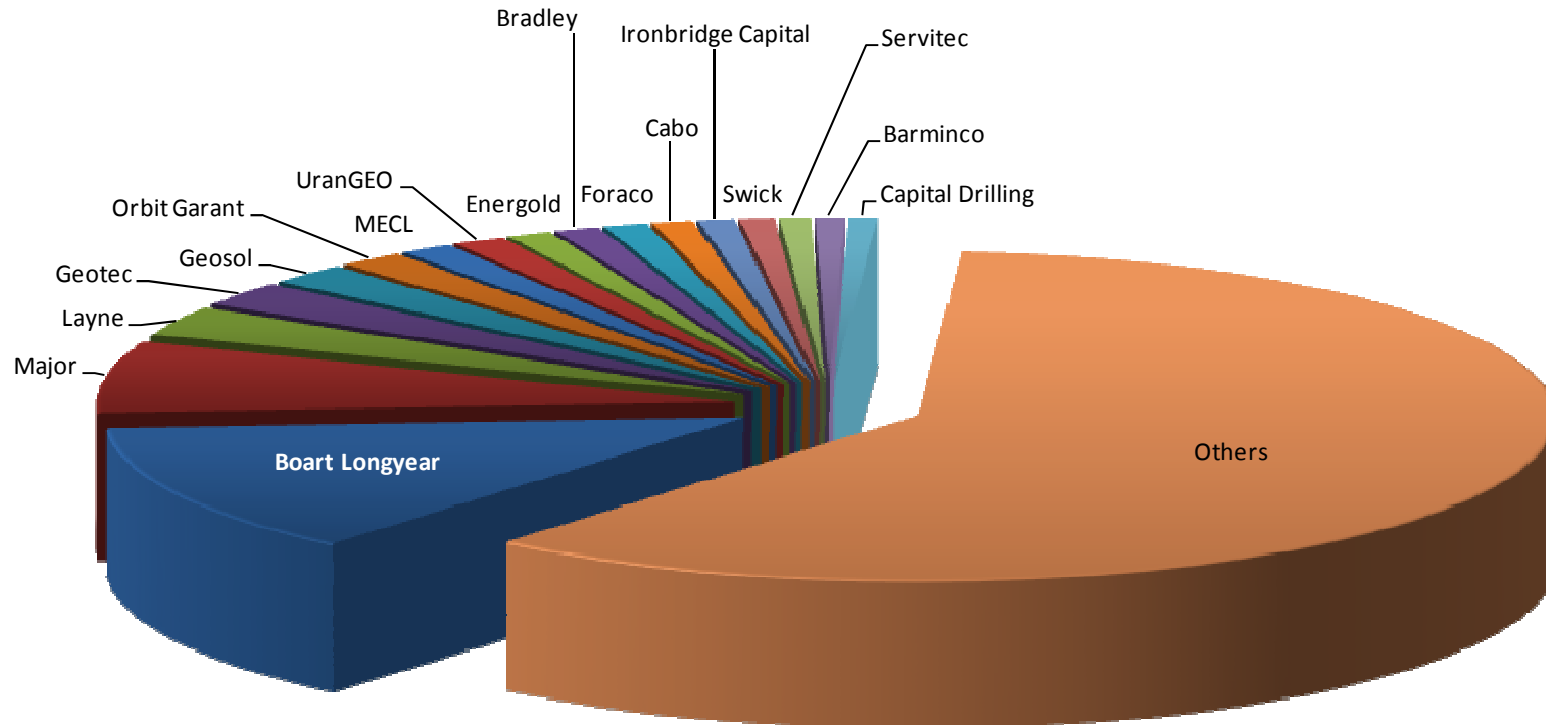

Types of Drilling

Core Drilling



Rotary/RC Drilling



Percussive Drilling



Environmental and Infrastructure (E&I) Drilling Services

Sonic Sampling Accuracy

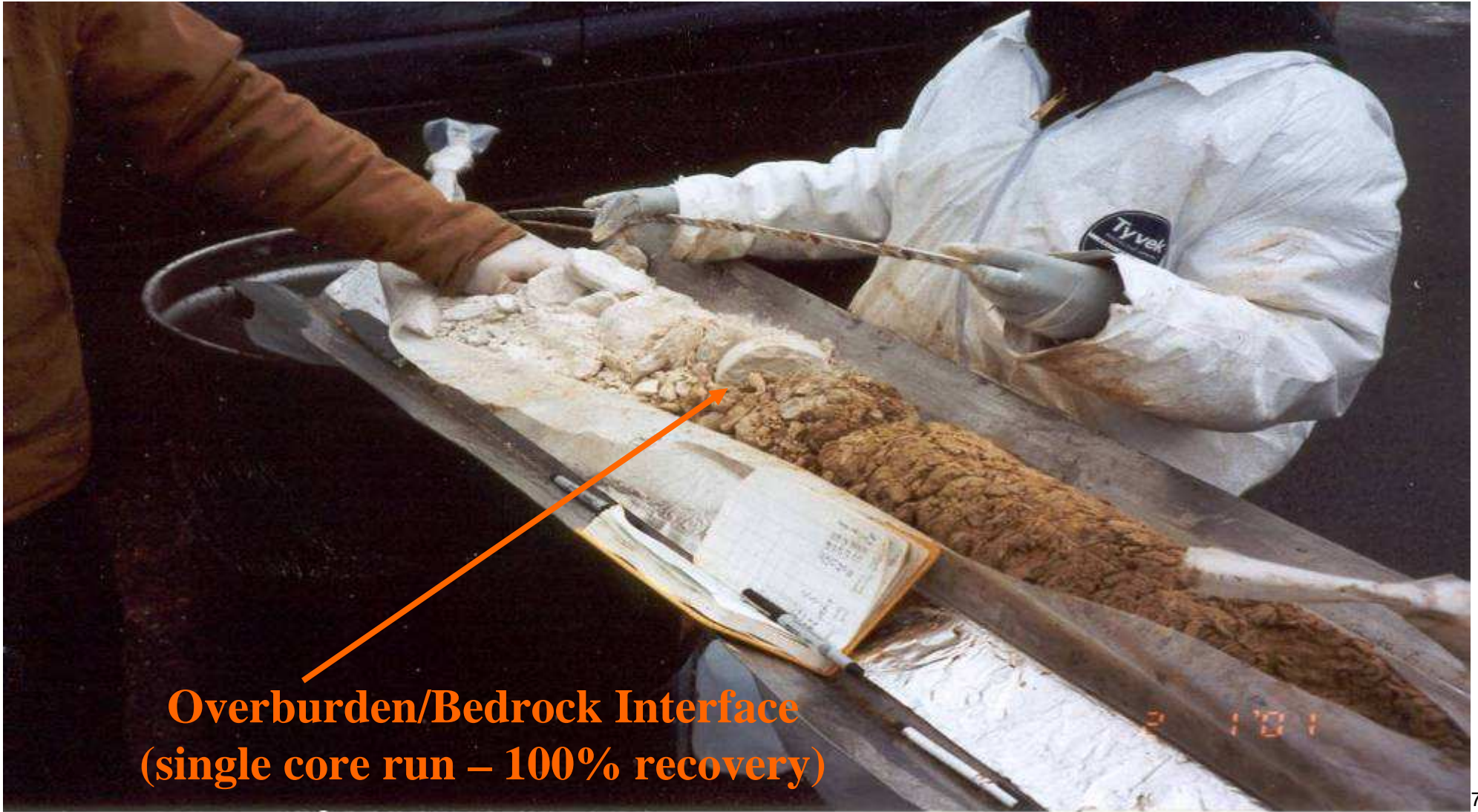

**Overburden/Bedrock Interface
(single core run – 100% recovery)**

SONIC Sampling Advantages

Continuous core samples



Sand and gravel



Cobbles and boulders



Bedrock

Served Market Segments - 2008 Revenue

“Value it”

“Clean it”

“Build it”

“Find it”

Minerals

Environmental

Infrastructure

Water

Crossover with M&E

Geotechnical

Geothermal

Geo Construction

Municipal/Industrial/Commercial

Determine Resource Value

Identification & Remediation

Sub-Surface Conditions

Closed Loop Heat Pumps

Ground Improvement

Water

% of 2008 Revenue

12%

66%

10%

6%

6%



Sonic Technology Overview

- utilizes high-frequency vibration
- oscillator creates vibration
- reduces friction on drill pipe

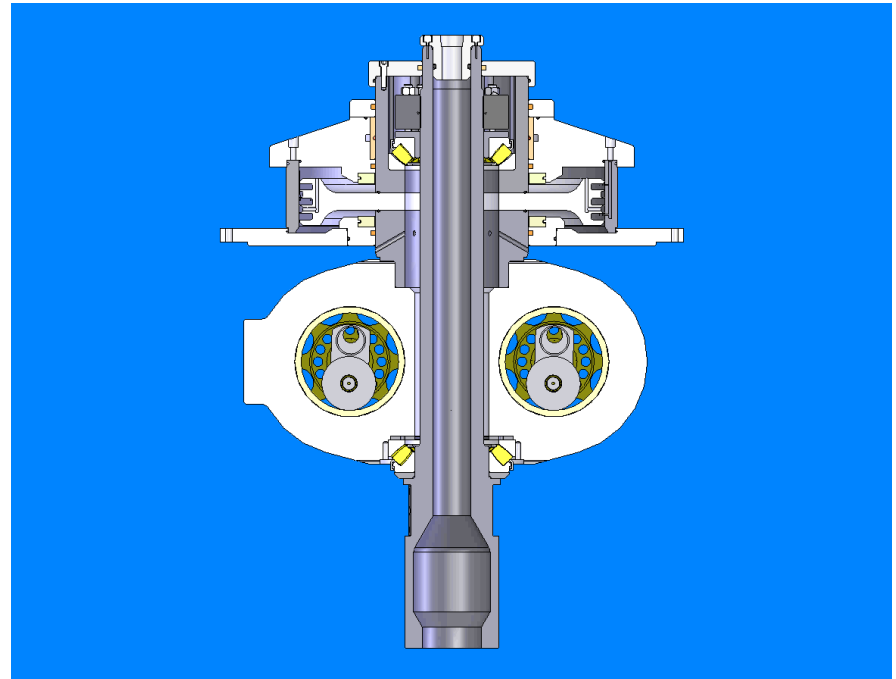
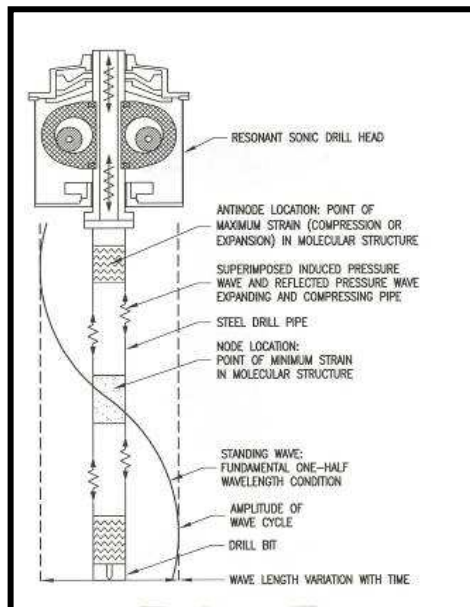

E&I Global Customers – Different Customer Base

E&I



Infrastructure, environment, buildings



Mining



resourcing the future



Investing in the Agricultural Super Cycle



Competitive Sonic Drillers

Sonic Competitors



Sonic Rig Count

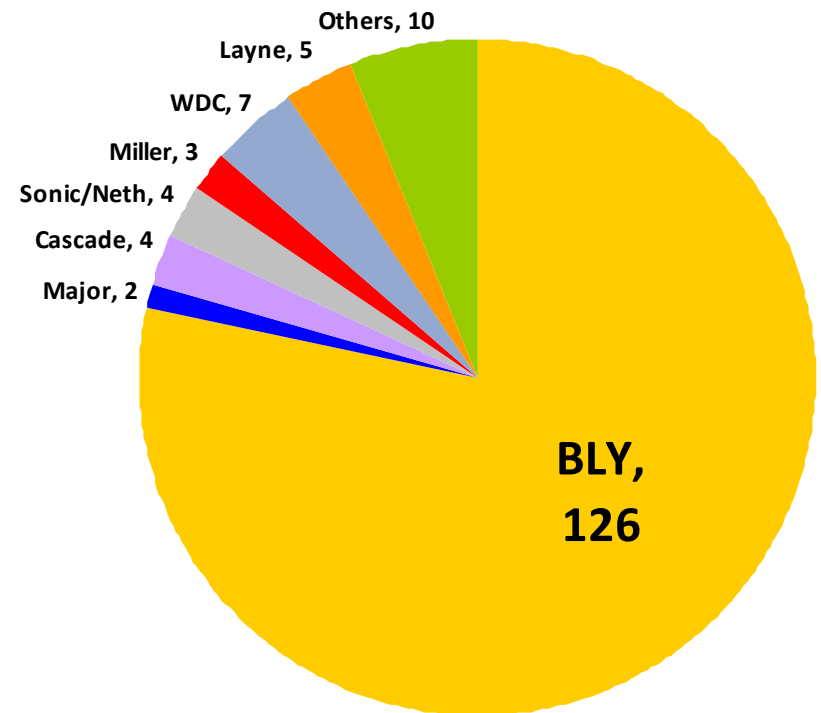

Drilling Products

PRODUCTS VALUE PROPOSITION

MINERAL & ENERGY

PRODUCTION

*ENVIRONMENTAL &
INFRASTRUCTURE*

*CAPITAL
EQUIPMENT*

*CONSUMABLE
TOOLING*



 **BOART LONGYEAR™**

3RD PARTY EXTERNAL CUSTOMERS

Diversified Markets

 4,890 Customers in 2008



Largest Customer = 3% of 2008 Revenues¹
Top 10 = 22% of 2008 Revenues¹



(1) 2008 Revenues Products Division Only

GLOBAL ENGINEERING

Technology Development and Innovation

 World Class Technology Development Structure

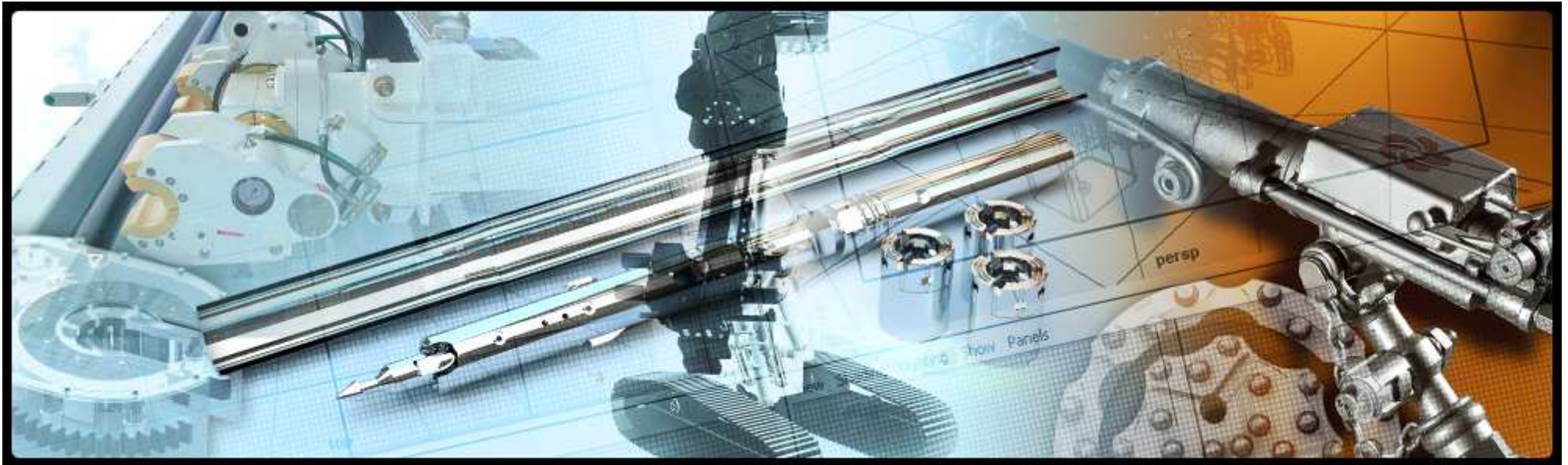

GLOBAL CENTERS OF EXPERTISE

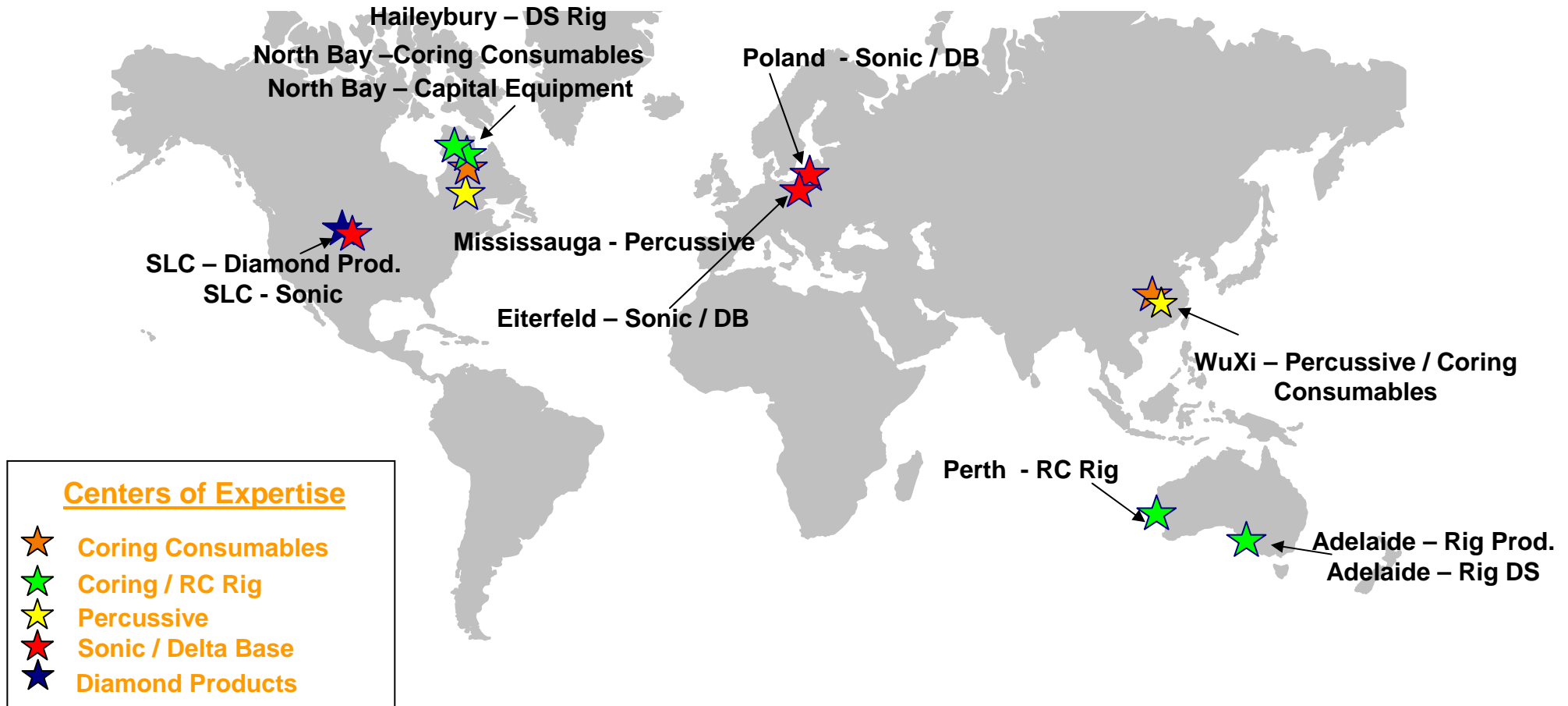

2009 TECHNOLOGY ROAD MAP

Drilling Products Innovations

 Coring Rig Technology

 Diamond / RC Rod Handling

 Industry leading Wireline Tooling

 Diamond Bits



Underground Wireline



4200 Diamond Coring Rig with Rod Handling



1200m Fly Coring Rig with Rod Handling



Diamond Bit

2009 TECHNOLOGY ROAD MAP

Drilling Services Innovations

🌀 Mobile Drill Rig (MDR) Underground Drill

🌀 Rod Handler to LF90D Truck Mount

🌀 Rod Spinner Breaker

🌀 Innovative Guarding Solutions

🌀 Industry Leading Sonic Technology



Mobile Drill Rig



Rod Handler to LF90D



Rod Spinner Breaker



Innovative Guarding



MDR

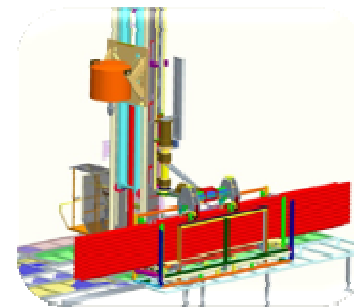

Sonic Rod Handling



Sonic Head

Our Competitive Difference

CONSUMABLES

CAPITAL EQUIPMENT

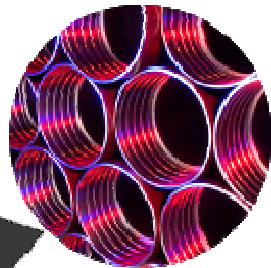

DRILLING SERVICES



Integrated Provider

- Integrated Minerals drilling solutions provider in the world.
- #1 Provider of Drilling Services to the Minerals Exploration Industry
- #1 Provider of Products to the Minerals Exploration Industry



Technology & Innovation Leadership

- Link between DS/Products provides direct input from the field – producing better solutions
- Time to market is greatly enhanced as product development/testing is all internal



**BOART
LONGYEAR**



INVESTOR RELATIONS

Telephone: 801-952-8513 Email: ir@boartlongyear.com
Web: <http://www.boartlongyear.com/web/guest/investors>